



Predictable, continuous and efficient power systems engineered for organisations with zero tolerance for downtime.



Single-Module **CLEANSOURCE®** UPS

battery-free energy storage

high reliability

98%

Efficiency

120 - 150 - 250

kVA

500 750

380/400/415

V

SYSTEM FEATURES

- Rugged, on-line and fault-tolerant UPS
- Most efficient UPS architecture
- Handles multi-load characteristics
- Cost-effective lifecycle cost
- Predictable flywheel energy storage
- 20-year design life
- Low service and maintenance requirements
- Smallest available footprint
- Rapid recharge time
- Predictive failure analysis
- Wide operating temperature range
- Remote and local monitoring
- Quiet operation
- Simple and cost-effective installation
- Field-proven reliability
- No hazardous waste material

PARALLEL ONLINE ARCHITECTURE

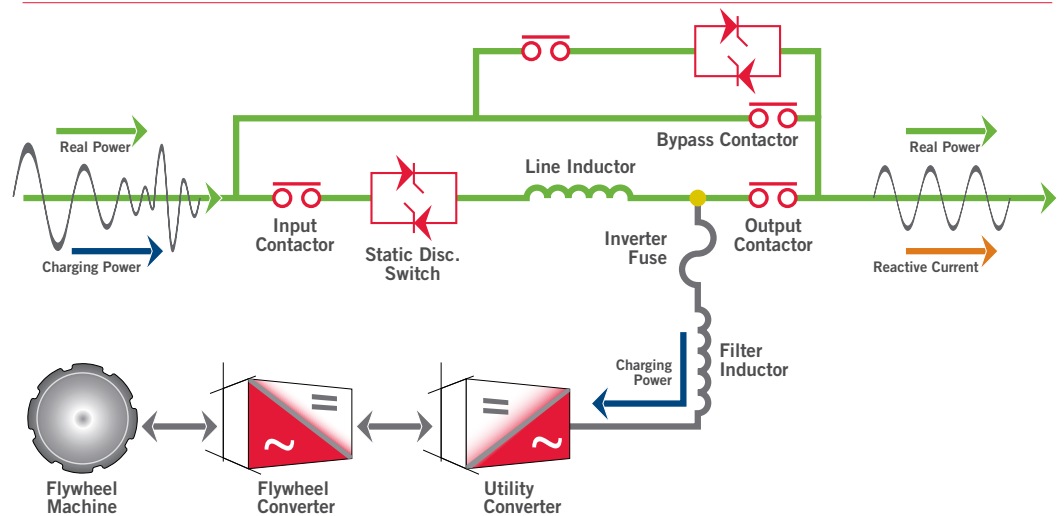

PRODUCT SPECIFICATIONS

MODEL	UPS 120i	UPS 150i	UPS 250i		
RATING					
Maximum kVA	120	150	250		
Maximum kW	120	135	225		
INPUT					
Voltage	380/400/415 VAC 3-phase, 4-wire plus ground (from grounded wye source)				
Voltage Range	+10% / -15% (programmable) +/- 10% at 380 VAC				
Frequency ¹	50 Hz +/- 10% maximum (programmable) +/- 3% (default)				
Power Factor	0.99 at rated load and nominal voltage				
Harmonic Current Distortion					
Linear Load	<3% at 100% load				
Non-Linear Load ²	<8% at 100% load				
Current - Nominal (380 VAC)	192	216	355		
Current - Nominal (400 VAC)	182	205	337		
Current - Nominal (415 VAC)	176	198	325		
Current - Max. Continuous	230	400	400		
Current - Max. Non-Continuous	290	400	420		
Surge Withstand	Meets IEEE 587/ANSI C62.41				
Walk-In	1 to 15 seconds (programmable)				
OUTPUT					
Voltage	380/400/415 VAC 3-phase, 4-wire plus ground				
Voltage regulation					
Steady state	+/-1% for +/-10% input				
Flywheel mode	+/-1% steady state				
Transient	+/-1% within 50 mSec for 100% load step				
Voltage distortion	<3% linear loads and <5% for 100% non-linear loads				
Frequency	50Hz (mains synchronised) (normal operation +/- 0.2% free running)				
Slew Rate	Adjustable from 0.2Hz/second to 3.0Hz/second				
Current - Nominal (380 VAC)	183	228	380		
Current - Nominal (400 VAC)	173	217	361		
Current - Nominal (415 VAC)	167	209	348		
Overload Capability-Mains Operation	Continuous Up to 105%	10 Min 125%	2 Min 150%	30 Sec 200%	10 mSec >200%
UPS Efficiency ⁴	97%	97%	98%		
Environmental					
Audible Noise	<70 dBA at 1m				
Temperature					
Operating	0 to 40° C				
Storage	-25 to 70° C				
Humidity	5% to 95% (non-condensing)				
Altitude ³	Up to 1,000 metre				
Emissions and Immunity	EN 50091-2				
Maximum Heat Rejection⁵					
kW	4.96	5.43	5.84		
BTU/Hr	16,940	18,524	19,946		
PHYSICAL DATA					
Height (w/o wireway or DC bus)	1,981 mm	1,981 mm	1,981 mm		
Width	1,641 mm	1,641 mm	1,641 mm		
Depth	865 mm	865 mm	865 mm		
Weight	2,200 kg	2,500 kg	2,500 kg		
Cable Entry	Top or Bottom				
Safety	EN64040-1-1				

¹ 60Hz Available
² EN59001-3
³ Derate operating temperature for higher elevations
⁴ DC energy storage offline
⁵ DC energy storage online

STANDARD RIDE-THROUGH TIMES (SECONDS)

Load%	120i	150i	250i
100%	27	24	15
75%	36	33	20
50%	52	47	30
25%	87	80	56

FACTORY INSTALLED EQUIPMENT

Standard

- CSView™ – advanced real-time monitoring
- IGBT-based UPS technology
- Flywheel energy storage
- Superior power conditioning
- High-speed voltage regulation
- Static bypass circuit
- User-friendly control panel
- Redundant cooling fans
- Redundant control power
- Power factor correction
- Intelligent self-diagnostics
- Serial connections
- Back-feed protection
- Harmonic cancellation

Optional

- Remote SNMP/MODBUS monitoring capability
- Remote status panel
- Seismic provisions
- GenSTART™ Generator Start Power

World Headquarters

2128 W. Braker Lane, BK12 • Austin, Texas 78758-4028
 Tel: 877.BUY.ACPW • Fax: 512.836.4511
 sales@activepower.com

EMEA • Active Power Solutions Ltd. (UK)

Unit 4A • Lauriston Business Park • Pitchill • Evesham
 Worcestershire WR118SN • United Kingdom
 Tel: +44 1386 870 006 • Fax: +44 1386 870 806
 emea@activepower.com